

STONE APPLIQUE



Emissione diretta.

Corpo in cemento grezzo di colorazione naturale ad elevata resistenza meccanica, prodotto con procedimenti artigianali e realizzato a mano. Micro porosità, texture, rilievi, screpolature, avvallamenti e variazioni cromatiche nel tempo valorizzano la naturalezza del materiale e sono testimonianza dell'unicità di ogni singolo manufatto. Diffusore trasparente di protezione LED in vetro temprato.

Alimentazione elettronica integrata 220-240V 50/60Hz.

Fornito con cavo di lunghezza 1500 mm e di sistema a tenuta stagna per la connessione elettrica.

Direct emission.

Body in raw concrete of natural colour with high mechanical resistance. Manufactured through craft processes and handmade. Micro porosity, texture, relief, cracks and chromatic variations through time, all enhance the authenticity of material and demonstrate the unique and bespoke feel of each individual piece. LED protected with a diffuser in tempered embossed glass.

Integrated electronic ballast 220-240V 50/60Hz.

Supplied with 1500 mm long cable with water proof protection for electrical connection.

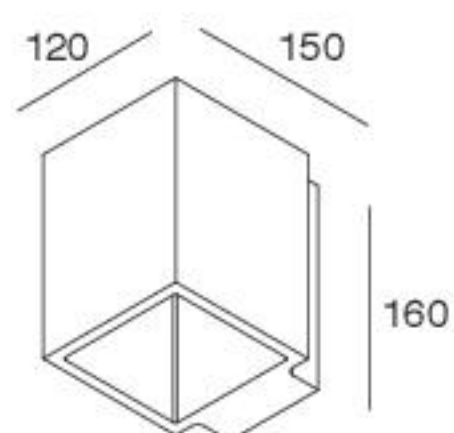

H (mm)	POWER	FLUX	3000K
160	7W	360 lm	103201.92