







## EOS

- Corpo in policarbonato V1 autoestinguente stabilizzato ai raggi UV
- Parabola in alluminio lucido puro al 99,85%
- Diffusore in policarbonato V1 autoestinguente stabilizzato ai raggi UV
- Viti di chiusura in acciaio inox A4
- Lampada esclusa
- IP54
- Isolamento in Classe I
- Omologazione CE

- Polycarbonate body V1 self-extinguishing and U.V. rays stabilized
- Bright aluminium reflector pure at 99,85%
- Diffuser in polycarbonate V1 self-extinguishing and U.V. rays stabilized
- Closing screws in stainless steel A4
- Lamp not included
- IP54
- Class I
- CE omologations

- Corps en polycarbonate V1 résistant au feu et stabilisé aux rayons ultra violets
- Réflecteur en aluminium brillant et pure 99,85%
- Diffuseur en polycarbonate V1 résistant au feu et stabilisé aux rayons ultra violets
- Vis en acier inoxydable A4
- Lampe pas inclus
- IP54
- Classe I
- Certification CE

**Finitura - Finishing - Finissage**

- |  |   |   |   |
|--|---|---|---|
|  | <b>.1</b> Antracite<br>Anthracite<br>Anthracite |  | <b>.4</b> Grigio (Ral 9006)<br>Grey (Ral 9006)<br>Gris (Ral 9006) |
|  | <b>.2</b> Bianco<br>White<br>Blanche            |  | <b>.8</b> Corten  |
|  | <b>.3</b> Nero<br>Black<br>Noir                 |   |   |

**Accessori - Accessories - Accessoire**

-  **F.97** Braccio in policarbonato per fissaggio a 45°  
(215x97x52mm)  
Polycarbonate bracket for fixing at 45°  
(215x97x52mm)  
Polycarbonate support pour fixation à 45°  
(215x97x52mm)

Esempio di ordinazione  
Configuration code  
Code de composition  
**F.6157 + .1**

13w 865 lumen  
4000°K CRI >80  
220-240V 50/60Hz

- Diffusore opale  
Opal diffuser  
Diffuseur opale

IP54  

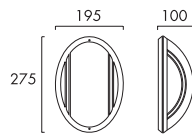

**Led option**

- **.28** 3000°K



**LED**



**F.6155**

FSQ 18W 1200 lumen  
230V 50Hz

- Diffusore opale  
Opal diffuser  
Diffuseur opale

IP54  

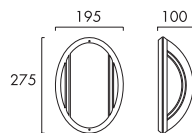

G24d-2

**F.6160**

**F.6160.HF**

Reattore elettronico  
Electronic ballast  
Réacteur électronique

FSQ 26W 1800 lumen  
230V 50Hz

- Diffusore opale  
Opal diffuser  
Diffuseur opale

IP54  

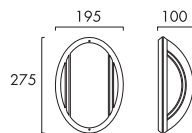

G24d-3

**F.6161**

**F.6161.HF**

Reattore elettronico  
Electronic ballast  
Réacteur électronique

FBT 23w 1520 lumen  
Osram Dulux Superstar Mini Twist  
230V 50Hz

- Diffusore opale  
Opal diffuser  
Diffuseur opale

IP54  

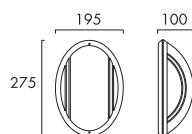

E27

**F.6157**

**F.6158**

Versione in classe   
Version class  
Version en class

**Finitura - Finishing - Finissage**

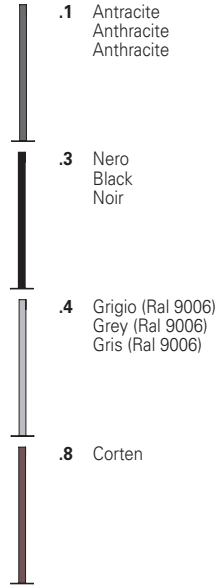

- .1** Antracite  
Anthracite  
Anthracite
- .3** Nero  
Black  
Noir
- .4** Grigio (Ral 9006)  
Grey (Ral 9006)  
Gris (Ral 9006)
- .8** Corten

**Accessori - Accessories - Accessoires**



**F.6179** Adattatore termoplastico per palo diametro 60 mm per un apparecchio  
 Thermoplastic adaptor for round pole diam. 60 mm for one fixture  
 Adaptateur en thermoplastique pour ronde poteau diam. 60 mm pour un appareil



**F.6180** Adattatore termoplastico per palo diametro 60 mm per due apparecchi  
 Thermoplastic adaptor for round pole diam. 60 mm for two fixtures  
 Adaptateur en thermoplastique pour ronde poteau diam. 60 mm pour deux appareils



**F.6166**

**F.6170**

**F.6174**

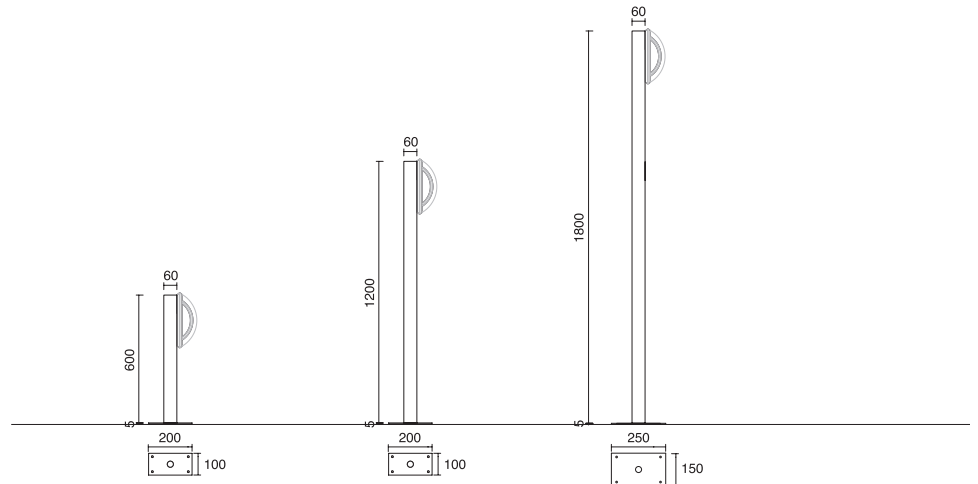

**F.6167**

**F.6171**

**F.6175**

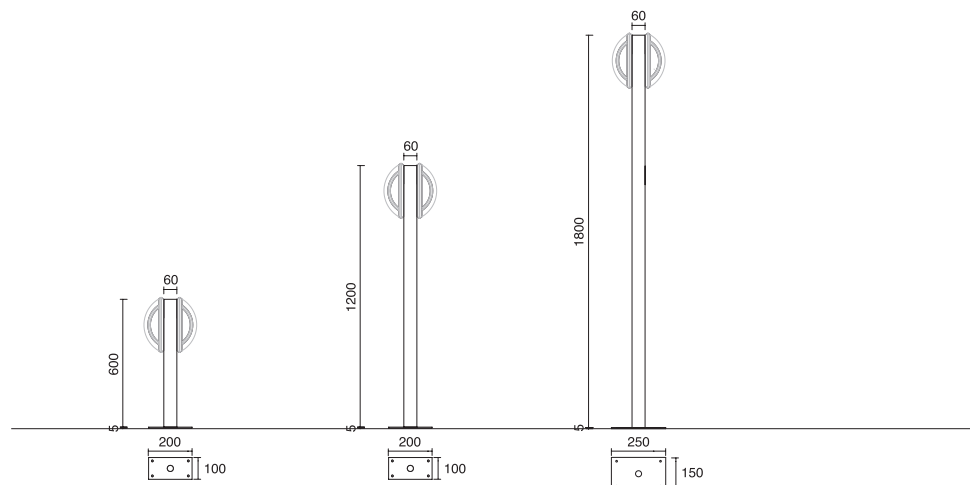

F.6168

F.6172

F.6176

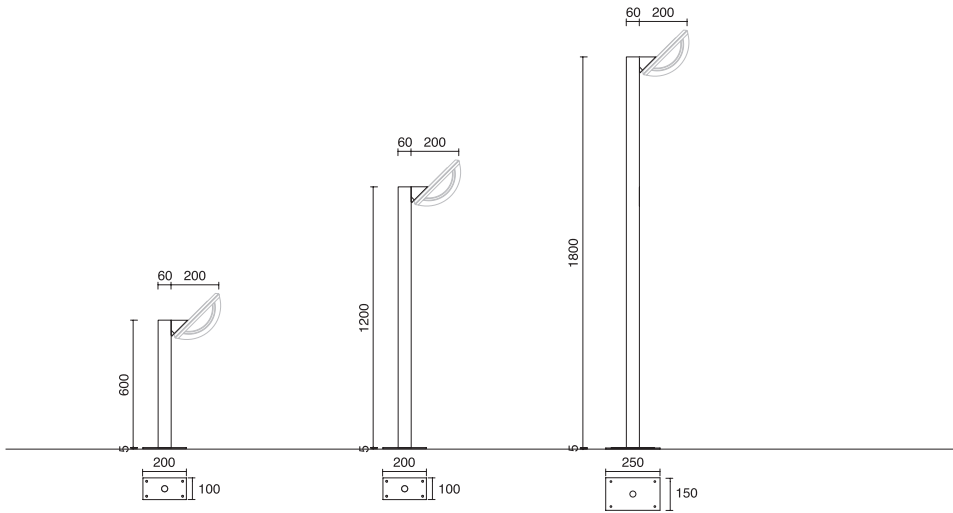

F.6169

F.6173

F.6177

